

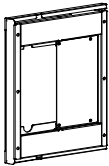



	Type	Q'ty		Type	Q'ty		Type	Q'ty		Type	Q'ty
A		1pc	D		4pcs	E		6pcs	F		1pc

Step 1: Pull-out the mechanism and swivel.

Step 2: Attach to partition using 4 euro screws(D), Top screw must be between 37.8" from the floor.

Step 3: Screw Ironing Board(F) to mechanism(A) using 6 machine screws(E).

Keep piston big head on top.

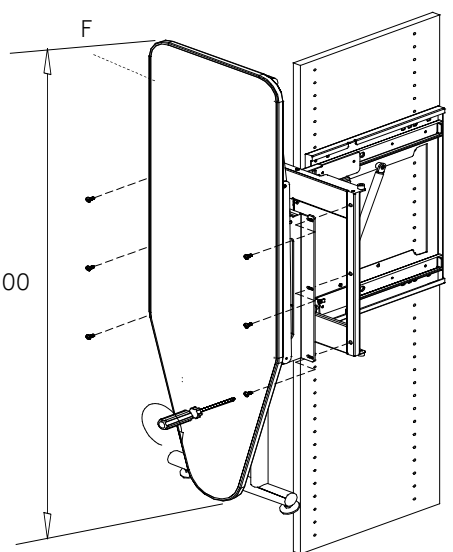
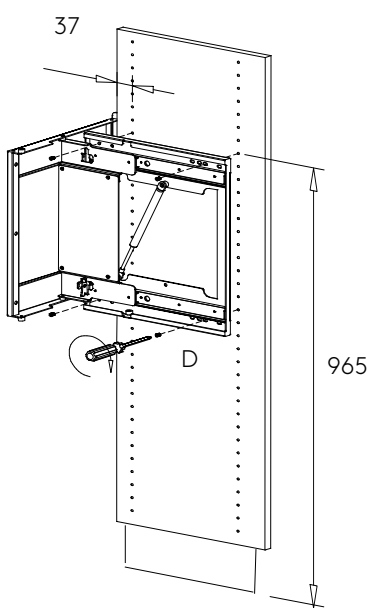
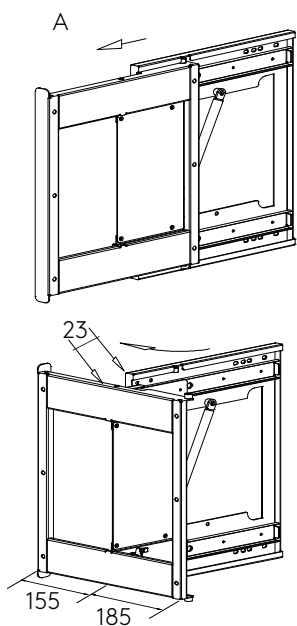



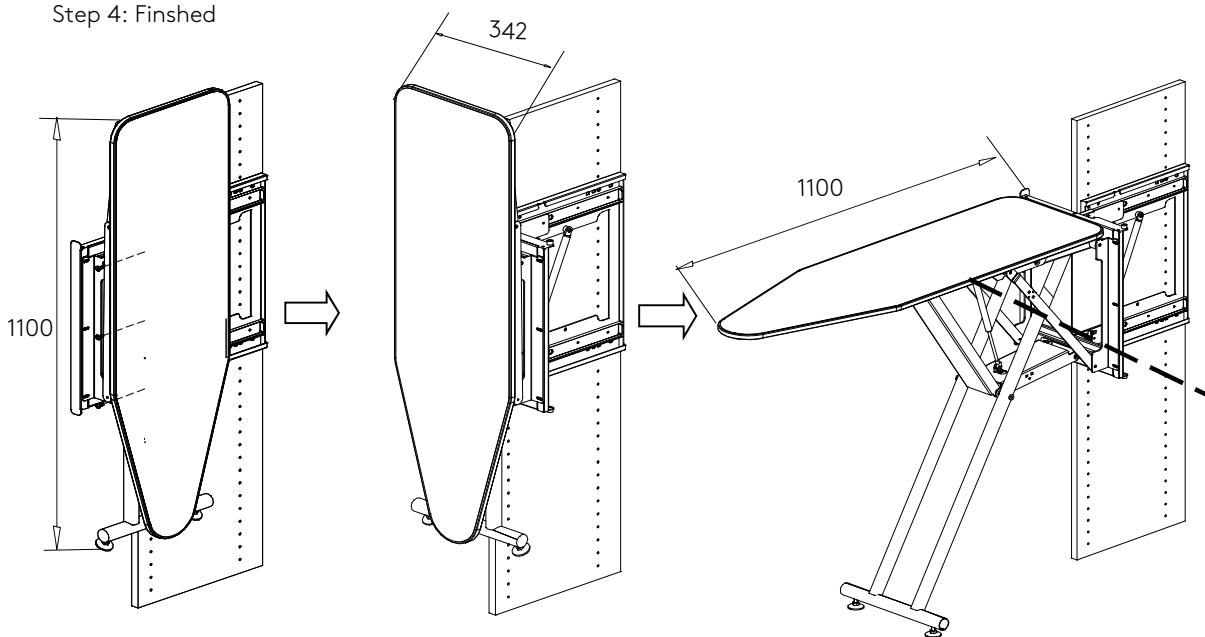

Step 4: Finished

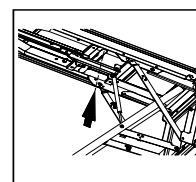
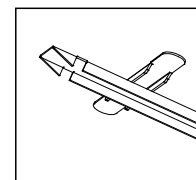

* Pull stopper to release
* Push board down to close

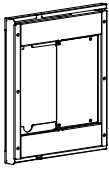

Suit 300mm wide module

	Type	Q'ty		Type	Q'ty		Type	Q'ty		Type	Q'ty
A		1pc	D		4pcs	E		6pcs	F		1pc

Step 1: Pull-out the mechanism and swivel.

Step 2: Attach to partition using 4 euro screws(D), Top screw must be between 37.8" from the floor.

Step 3: Screw Ironing Board(F) to mechanism(A) using 6 machine screws(E).

Keep piston big head on top.

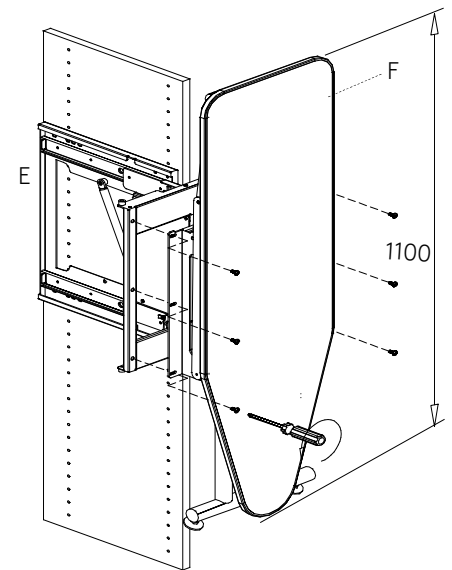
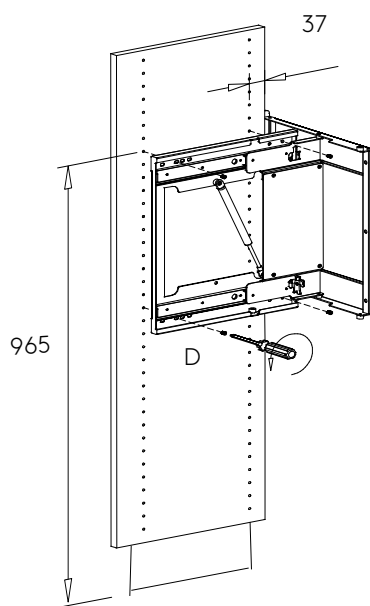
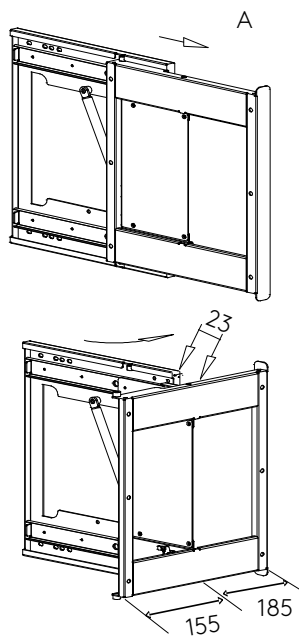

Step 4: Finished

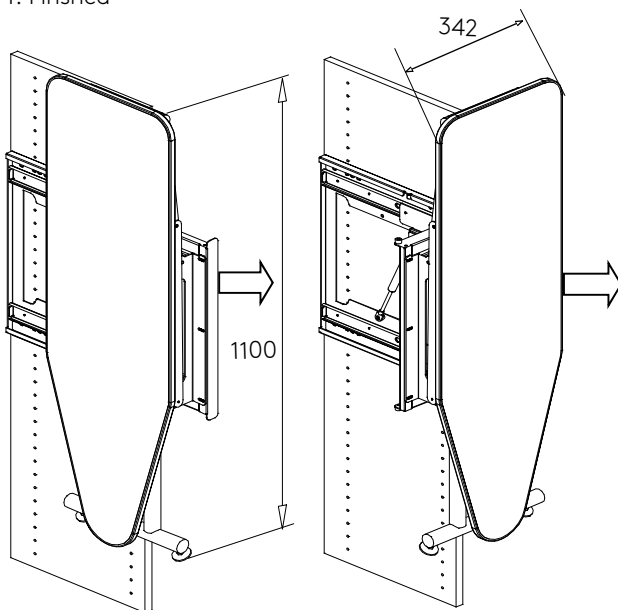

* Pull stopper to release
* Push board down to close

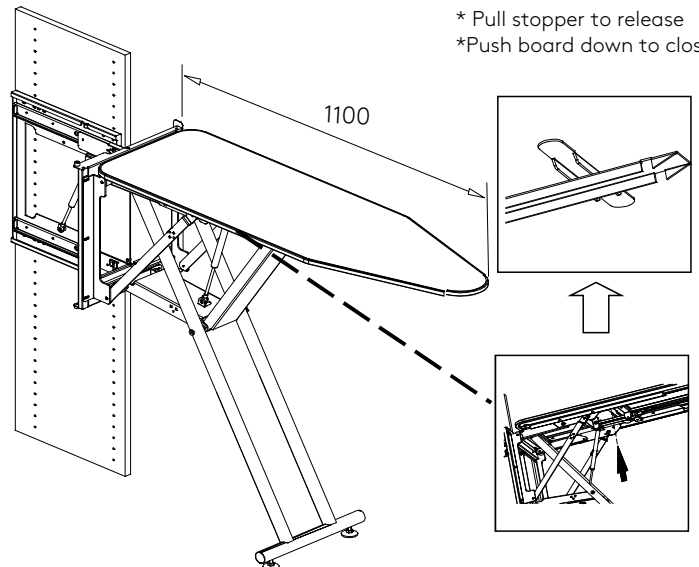

Suit 300mm wide module

