



AP-5B70M0730AU 60cm Built-in Oven

Features & Benefits

Easy Cleaning

Removable door, enamelled smooth oven walls and suspended grills for easy cleaning.

Modern Aesthetics

Touch control panel and sleek black glass finish to make your kitchen look flash.

Heat Trap

Full glass inner door combined with two internal oven light for viewing so there is no need to open the door, releasing the heat.

Energy Efficient

Energy efficiency class A+. 220-240 V with a total connected load 2.9kW.

Meat Probe

Additional function to help regulate oven temperature. Probe sold separately.

Child Safe

Triple glazed glass creates a low door temperature which prevents serious burns from accidental contact. Childproof lock function for families.

12 Functions

- | | |
|------------------------|---------------|
| Conventional Grill | Convection |
| Double grill | Pizza mode |
| Double grill fan force | Defrost |
| Bottom heat | Preheating |
| Conventional fan force | ECO |
| | Dough proving |

Display and Controls

Touch control panel and display

Heating

Electric

Timer

Off, On, Alarm

Specification

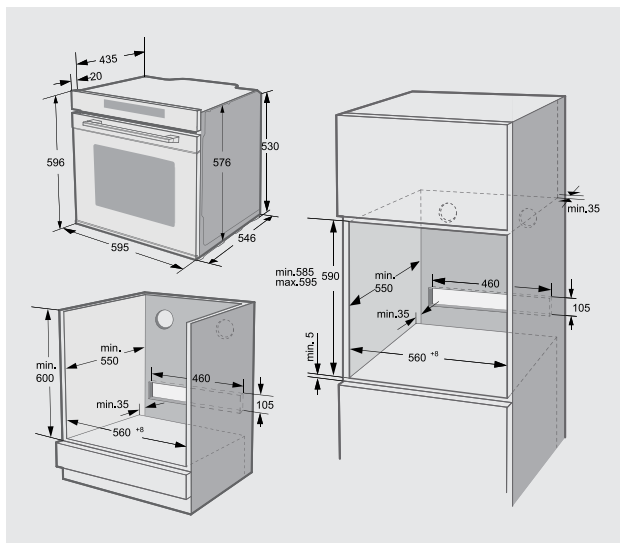

Dimensions

Appliance: H595 x W565 x P595mm
Installation: H600 x W560 x P550mm

Screen Height

96mm

Weight

Net: 32 kg

Volume

Net: 72 litres

Type

Built-in

Material

Door: Glass
Panel: Stainless Steel
Oven walls: Enamel

Finish

Stainless Steel & Black

Built-in Lights

2

Connection

- Energy consumption conventional heating - oven 1: 1.06 kWh
- Energy consumption convection/hot air - oven 1: 0.69 kWh
- Hedging: 12.6 A at 230V
- Voltage: 220-240 V
- Frequency: 50-60 Hz
- Plug type: no plug
- Front color: Glass
- Energy source: Electric
- Approval certificates: CE, CB
- Length of power cable: 100 cm
- Net weight: 32.0 kg
- Gross weight: 34.5 kg

Accessories



Combination grate



Enameled baking tray