



AP-5DA15150AU 52cm Fan Module

Features & Benefits

Easy Cleaning

Stainless steel finish makes it easy to wipe off food splatters. Grease filters are dishwasher safe for quick cleaning.

Vision Comfort

Warm lighting with wide downward illumination creates a comfortable work station.

Hearing Comfort

Noise level as loud as washing machine, provides extraction without too much noise inconvenience.

Controls

Push button controls located on the base of the appliance.

Stylish

The appliance is integrated to the kitchen, making it more elegant.

Energy Efficient

Class B efficiency with average yearly consumption of 44.7kWh.

Programs

Extraction mode with 3 power levels
Recirculation mode (requires carbon filter)

Energy Source

Electricity

Specification

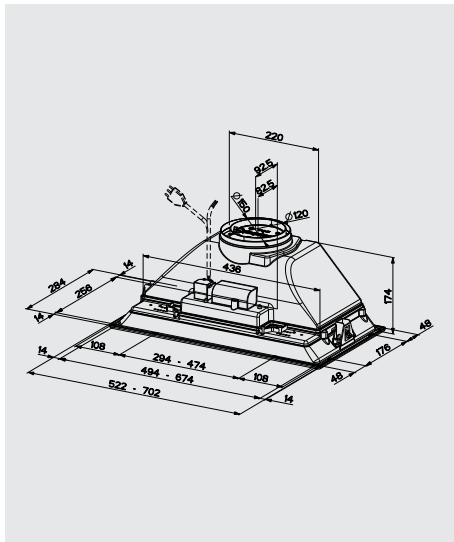

Dimensions

Appliance:
H174 x W522 x D284mm

Material

Grease filter: Aluminium
Surface: Stainless Steel

Finish

Stainless steel

Grease Filter

Dishwasher safe: Yes
Type: Cassette
Odour filter: Optional

Weight

Net: 7kg

Type

Built-in

Control

Electronic

Lighting

4W LED lamps x 2
Temperature: 3,000K
Illuminance: 100 lux

Extraction

Direction: Upward
Power: 600-640m³/h

Noise

Minimum: 54dB
Maximum: 70dB

Connection

- Voltage: 220-240 V
- Total connected load: 118 W
- Frequency: 50 Hz
- Installation: Built-in
- Energy Source: Electric
- Gross weight: 7kg
- Approval certificates: CE, VDE
- Required distance from induction hob: 500mm
- Required distance from gas hob: 650mm
- Appliance dimensions: 174 x 522 x 284mm
- Installation dimension: 305 x 605 x 370mm
- Exhaust air outlet area: 150 x 120mm
- Height of the unit without chimney: 175mm
- Length of connection cable: 150cm
- Connection type: Australian
- Position of fan: Motor in the housing
- Flow direction: Upwards
- Maximum sound power: 70dB
- Number of lamps: 2 LED lamps
- Total power of lamps: 8W

Accessories

