



AP-5IX99290AU

90cm Induction Cooktop with Integrated Extractor Fan

Cooktop Datasheet

Features & Benefits

Easy Cleaning

Frameless, flush installation to reduce cleaning surface. Glass top means a regular kitchen surface cleaner should be enough.

Efficiency

Pot detection switching for less panel operation. Cooking zone booster for quick heating. Zone linking possible for a larger cooking zone.

Cooking Assist

Timer and countdown function available.

Stylish Design

Sleek glass look in black colour that suits any modern style.

Space Saving

Flush installation integrates the surface for a wider workstation space. Slim and flat design requires less space for installation.

Safety Feature

Child lock and residual heat indicators to avoid accidents. A safety switch off is available in case of emergency.

Multiple Cooking Zones

4 zones that can be simultaneously used. Zone linking is possible between 2 adjacent zones.

Display and Controls

Touch control panel and 7-segment digital LED display located in front. Electronic control in 10 power levels.

Energy Source

Electricity

Specification

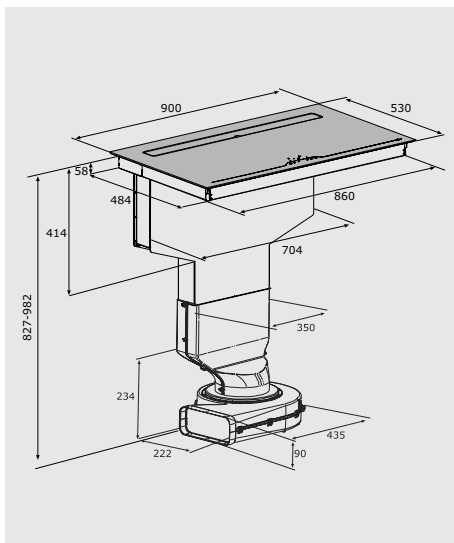

Dimensions

Appliance:
H827-982 x
W900 x D530mm
Installation:
H58 x W8.2 x D495mm

Material

Surface: Glass ceramic

Weight

Net: 30.8kg

Type

Built-in, frameless
combi-induction

Finish

Black

Cooking Zone Power (+Booster)

4 zones Ø 22cm
- 2.1 kW (3.7kW)

Control

Touch control panel
located in front
Pot detection

Display

LED display with 7
segments
Residual heat indicator

Connection

- Voltage: 220-240 V
- Total connected load: 8 kW
- Frequency: 50/60 Hz
- Device color: Black
- Energy Source: Electric
- Approval certificates: CE, RCM
- Packaged unit dimensions:
- Niche dimensions:
- Device width: 900mm
- Dimensions of the device: 55 x 590 x 520 mm
- Length of connection cable: 150cm
- Plug type: without plug

Accessories





AP-5IX99290AU

90cm Induction Cooktop with Integrated Extractor Fan

Extractor Fan Datasheet

Features & Benefits

Easy Cleaning

Glass surface means a regular kitchen surface cleaner should be enough. Removable water collection tank and dishwasher friendly grease trap for easy cleaning.

Efficiency

Control panel is in front of the unit, no need to reach into the extractor fan to operate.

Automation

Automatic overrun for circulation mode and 3-level overrun for 5/10/20 minutes. Blocks collection tank after 40 hours of operation.

Stylish Design

Sleek glass look in black colour that suits any modern style. Downward suction frees up space above the cooktop for a minimalistic design.

Space Saving

Compact design makes it suitable for installation in a kitchenette or kitchen island.

Quiet but Powerful

Wide opening allows for huge amount of extraction without being too loud.

Modes

Extraction
Circulation (carbon filter required)

Display and Controls

Touch control panel and 7-segment digital LED display located in front. Electronic control in 5 power levels plus 1 intensive level.

Energy Source

Electricity

Specification

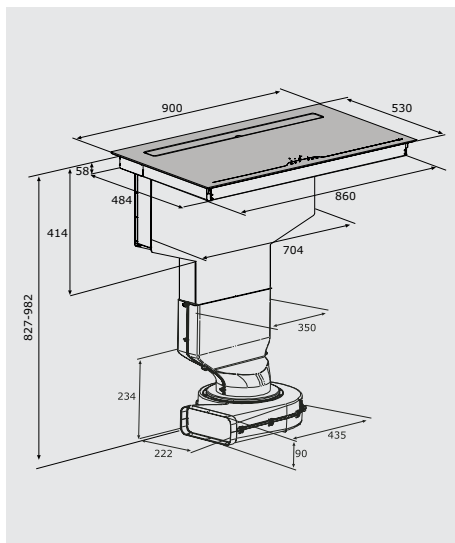

Dimensions

Appliance:
H827-982 x
W900 x D530mm
Installation:
H58 x W8.2 x D495mm

Material

Surface: Glass ceramic

Weight

Net: 30.8kg

Finish

Black

Noise

Minimum: 45dB(A)
Maximum: 65dB(A)
Intensity: 70dB(A)

Fan Output

Extraction: 580m³/h
Circulation: 450m³/h

Intensity Level

Extraction: 730m³/h
Circulation: 560m³/h

Grease Filter

Metal grease filter
Efficiency: Class B

Collection Tank

Capacity: 0.75L

Display

LED display

Extraction

Downward

Connection

- Voltage: 220-240 V
- Total connected load: 0.165kW
- Frequency: 50/60 Hz
- Device color: Black
- Energy Source: Electric
- Approval certificates: CE, RCM
- Packaged unit dimensions:
- Niche dimensions:
- Device width: 900mm
- Dimensions of the device: 55 x 590 x 520 mm
- Length of connection cable: 150cm
- Plug type: without plug

Accessories

