

look inside



**nikpol**<sup>™</sup>

dtc c82 stylish hinge



# c82 110° hinge

With its elegant and slim design and miniature damper technology, DTC C82 hinge opens your stylish and functional Blaupunkt fridges into endless possibilities. Assembly comfort is the new benchmark. The intuitive anyway snap-on technique simplifies and speeds the process of mounting cabinet doors. Featuring an 11.5mm hinge cup depth and a 35mm diameter, it accommodate doors ranging from 16mm to 26mm in thickness.

## hinges & plates

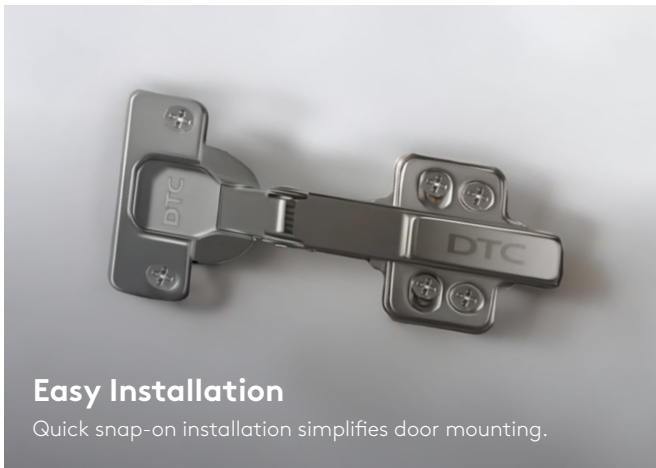

### Easy Installation

Quick snap-on installation simplifies door mounting.

## integrated soft close hinges

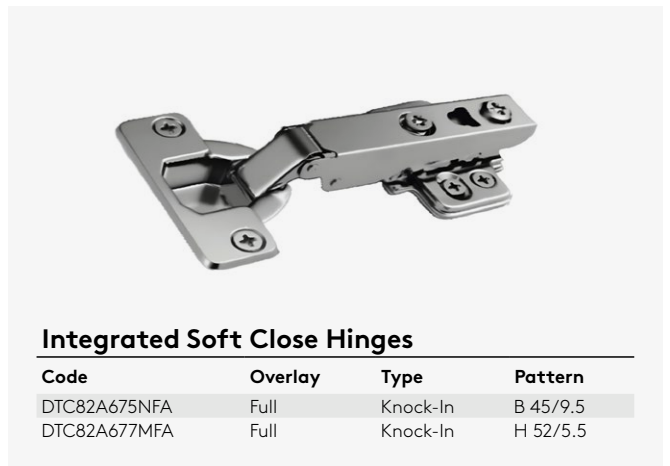

### Integrated Soft Close Hinges

Code	Overlay	Type	Pattern
DTC82A675NFA	Full	Knock-In	B 45/9.5
DTC82A677MFA	Full	Knock-In	H 52/5.5

## hinge plate

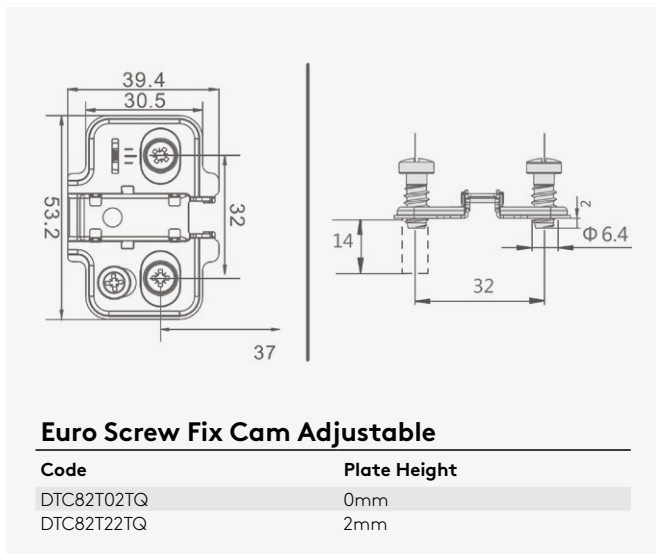

### Euro Screw Fix Cam Adjustable

Code	Plate Height
DTC82T02TQ	0mm
DTC82T22TQ	2mm

## compatible with blaupunkt integrated fridge

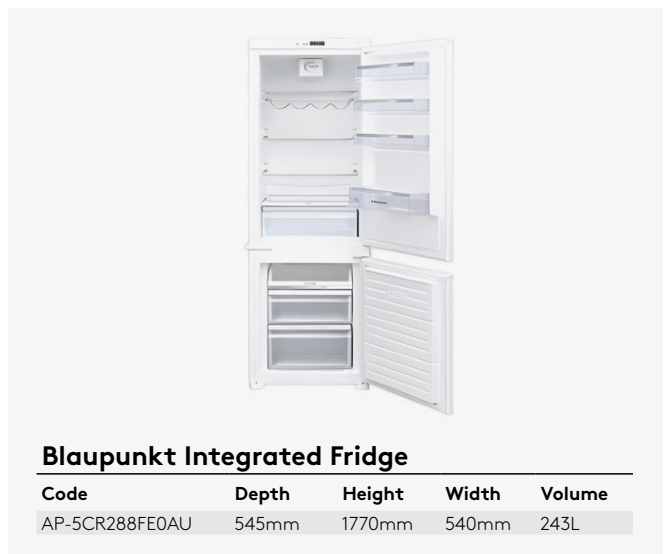

### Blaupunkt Integrated Fridge

Code	Depth	Height	Width	Volume
AP-5CR288FE0AU	545mm	1770mm	540mm	243L

# specifications

## plate height calculation

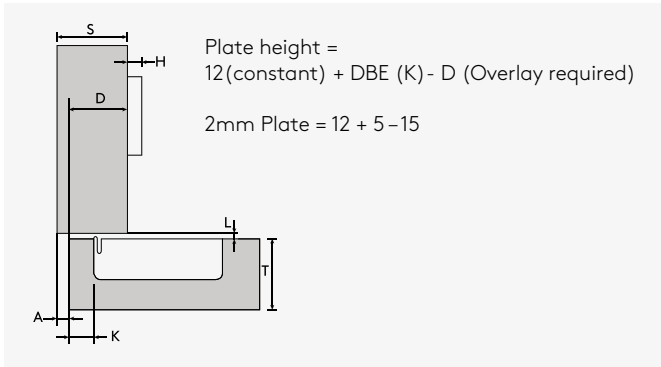

## projection of the door

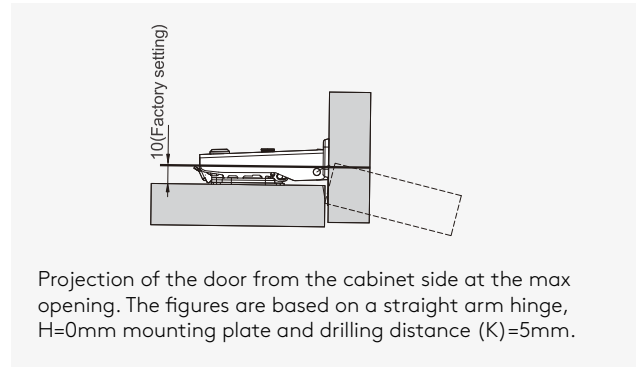

## space needed to open the door

T= Door thickness

K= Cup hole drilling distance from door edge

	T=	16	17	18	19	20	21	22	23	24	25	26
K=3	A=	0.7	0.9	1.1	1.4	1.8	2.1	2.6	3.1	3.7	4.4	5.2
K=4	A=	0.7	0.9	1.1	1.4	1.7	2.0	2.5	2.9	3.4	4.1	4.8
K=5	A=	0.6	0.8	1.1	1.3	1.6	2.0	2.4	2.8	3.3	3.8	4.5
K=6	A=	0.6	0.8	1.0	1.3	1.6	1.9	2.3	2.7	3.1	3.7	4.2

	T=	16	17	18	19	20	21	22	23	24	25	26
K=3	L=	0.0	0.0	0.0	0.0	0.0	0.3	0.5	0.8	1.1	1.3	1.6
K=4	L=	0.0	0.2	0.4	0.7	1.0	1.2	1.5	1.8	2.0	2.3	2.6
K=5	L=	0.9	1.1	1.4	1.7	1.9	2.2	2.5	2.7	3.0	3.3	3.5
K=6	L=	1.8	2.1	2.4	2.6	2.9	3.2	3.4	3.7	4.0	4.2	4.5

The above values are calculated on the assumption that the doors have square edges. They are reduced if the doors have radiused edges.

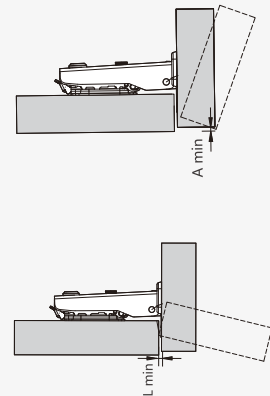

## Ø 35mm hinge cup types

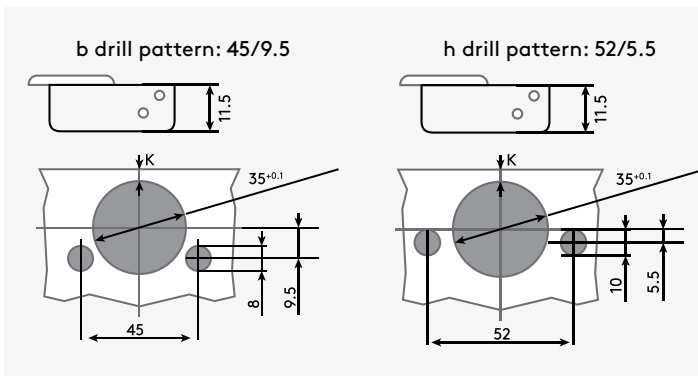

Use these formulas to determine the type of hinge arm, drilling distance (K=5mm), and the height of the mounting plate (H=2mm) for each door application.

# nikpol<sup>®</sup>

**Nikpol Pty. Ltd.**

**DTC C82 Hinge 2025**

The colours shown in this flyer are an indication of the actual colour, for the most accurate colour-match sample, please visit the Nikpol website to order colour samples at [www.nikpol.com.au](http://www.nikpol.com.au)

Prices are subject to change after the promotions ends. Offer valid while stocks last.

**Tel** 1300 645 765  
**Web** [www.nikpol.com.au](http://www.nikpol.com.au)  
**Email** [sales@nikpol.com.au](mailto:sales@nikpol.com.au)

**Head Office (VIC)**  
6-12 Fairchild Street  
Heatherton VIC 3202

**QLD**  
19 William Farrior Place  
Eagle Farm QLD 4009

[f @nikpolptyltd](#) [@ @nikpolaustralia](#) [# #nikpol](#) [/company/nikpol/](#) [@ @nikpolptyltd](#) [@ @nikpolaustralia](#)