



Alento SAG8600CE  
**ALENTO-ES1590**

**Features & Benefits**

**Hygienic**

Built to prevent bacteria growth and promote effortless maintenance, and ensure easy cleaning for lasting hygiene.

**Scratch resistant**

A scratch-resistant sink designed to withstand everyday use, maintaining its smooth surface and appearance over time.

**Durable**

Engineered for long-lasting durability, this material combines exceptional scratch resistance with an easy-to-care-for surface, ensuring it retains its pristine appearance and functionality over time.

**Colour and food**

Crafted with food-safe, non-toxic materials, this surface is designed to maintain its vibrant color while ensuring safety and suitability for direct contact with food.

**Easy to clean**

Sinks designed for effortless cleaning and lasting hygiene.

**Heat resistant**

Capable of withstanding high temperatures without damage ensuring long-lasting performance.

**Food safe**

Ideal for food preparation environments, meeting high hygiene standards and being easy to clean.

**Impact resistant**

Constructed to absorb heavy impacts effectively while maintaining its structure and resilience over time.

**Specification**

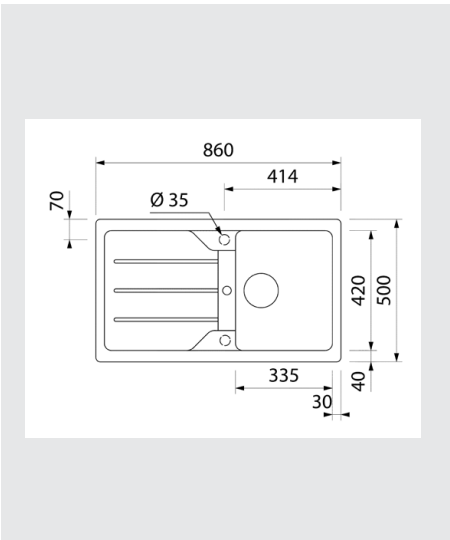

**Dimensions**

Sink bowl height: 19cm  
Sink base unit min required: 50cm  
Basin size: H190 x L420mm x D335mm  
External dimensions:  
W860 x D500mm

**Volume**

Capacity: 26L

**Design**

Material: Quartz composite  
Colour: Black granite

**Operating comfort & equipment**

Operation: Manual control  
Drain: Sieve basket valve 3 1/2"  
Drilling/Rated break points: With rated break points for fitting and excenter

**Construction type**

Top mounted