



## Alento SAG9600CE **ALENTO-ES1690**

### Features & Benefits

#### Hygienic

Built to prevent bacteria growth and promote effortless maintenance, and ensure easy cleaning for lasting hygiene.

#### Scratch resistant

A scratch-resistant sink designed to withstand everyday use, maintaining its smooth surface and appearance over time.

#### Durable

Engineered for long-lasting durability, this material combines exceptional scratch resistance with an easy-to-care-for surface, ensuring it retains its pristine appearance and functionality over time.

#### Colour and food

Crafted with food-safe, non-toxic materials, this surface is designed to maintain its vibrant color while ensuring safety and suitability for direct contact with food.

#### Easy to clean

Sinks designed for effortless cleaning and lasting hygiene.

#### Heat resistant

Capable of withstanding high temperatures without damage ensuring long-lasting performance.

#### Food safe

Ideal for food preparation environments, meeting high hygiene standards and being easy to clean.

#### Impact resistant

Constructed to absorb heavy impacts effectively while maintaining its structure and resilience over time.

### Specification

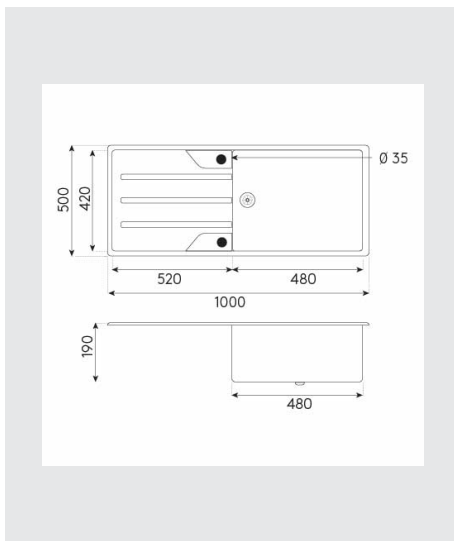

#### Dimensions

Sink bowl height: 19cm  
Sink base unit min required: 60cm  
Basin size: H190 x L480mm x D420mm  
External dimensions:  
W100 x D500mm

#### Volume

Capacity: 38L

#### Design

Material: Quartz composite  
Colour: Black granite

#### Operating comfort & equipment

Operation: Manual control  
Drain: Sieve basket valve 3 1/2"  
Drilling/Rated break points: With rated break points for fitting and excenter

#### Construction type

Top mounted  
Reversible