



AP-5MG17190AU 60cm Black Glass Built-in Microwave

Features & Benefits

Easy Cleaning

Removable turntable for easy cleaning access.

Safety Feature

Child safety lock available to avoid accidents. Appliance does not operate if door is open.

Modular

Same width as most Blaupunkt appliance and black front makes it easy to pair with other kitchen appliances.

Controls and Display

Touch panel to operate with red LED display for timer, function indicator and clock.

Functions

10 Automatic programs
Defrost by weight/time
Microwave power levels:
100W, 300W, 500W, 800W, 1000W
Grill power level:
1100W, 2300W

Energy Source

Electricity

Specification

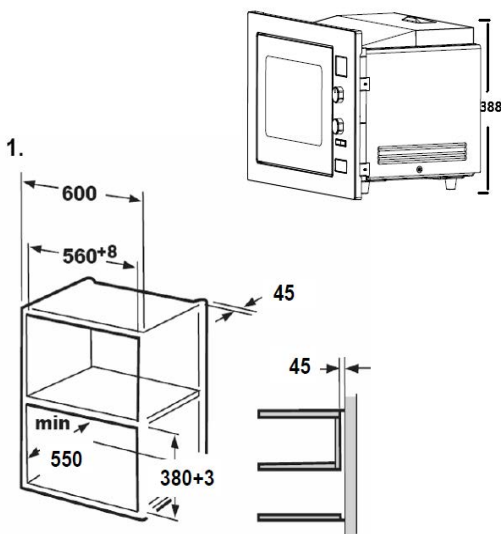

Dimensions

Appliance:
H388 x W595 x P470mm

Cavity:
H351 x W358 x P249mm

Material

Surface: Stainless Steel
Cavity: Stainless Steel
Turntable: Glass

Weight

Net: 22kg

Type

Built-in microwave

Finish

Black

Heating

Fan heater with 3 levels from 30-80°C

Control

Touch panel control

Door

Push button to open

Turntable

Ø315mm round glass

Display

Red LED digital display

Capacity

Volume: 34L

Connection

- Maximum micro-wave power: 1000W
- Current: 9.6 A at 240 V
- Voltage: 240 V
- Frequency: 50 Hz
- Device color: Stainless steel
- Energy Source: Electric
- Approval certificates: CE, CB, SAA
- Gross weight: 25kg
- Connecting cable: 1m
- Plug type: SAA

Accessories

