



Fiora SFG7490NE FIORA-ES1200

Features & Benefits

Hygienic

Built to prevent bacteria growth and promote effortless maintenance, and ensure easy cleaning for lasting hygiene.

Scratch resistant

A scratch-resistant sink designed to withstand everyday use, maintaining its smooth surface and appearance over time.

Durable

Engineered for long-lasting durability, this material combines exceptional scratch resistance with an easy-to-care-for surface, ensuring it retains its pristine appearance and functionality over time.

Colour and food

Crafted with food-safe, non-toxic materials, this surface is designed to maintain its vibrant color while ensuring safety and suitability for direct contact with food.

Easy to clean

Sinks designed for effortless cleaning and lasting hygiene.

Heat resistant

Capable of withstanding high temperatures without damage ensuring long-lasting performance.

Food safe

Ideal for food preparation environments, meeting high hygiene standards and being easy to clean.

Impact resistant

Constructed to absorb heavy impacts effectively while maintaining its structure and resilience over time.

Specification

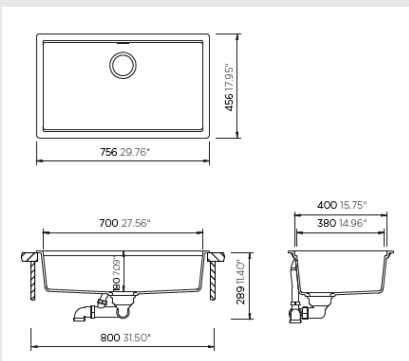

Dimensions

Sink bowl height: 18cm
Sink base unit min required: 80cm
External dimensions:
W756 x D456mm

Volume

Capacity: 50L

Design

Material: Quartz composite
Colour: Black granite

Operating comfort & equipment

Operation: Manual control
Drain: Sieve basket valve 3 1/2"

Construction type

Top mounted