



5WS16401
Warming drawer
Black glass with stainless steel application

Output, consumption

- Voltage: 220 – 240 V
- Frequency: 50 / 60 Hz
- Total connected load: 0.4 kW

Oven type, heating type

- Heating by fan heater
- Temperature regulation in 3 levels: from 30 °C – 80 °C
- 20.5 l interior volume
- Rotary switch on inside

Equipment / comfort

- Black glass front with stainless steel application
- Opens without handles by push & pull
- Telescopic full extension
- Anti-slip mat
- Dish pre-heating
- Food warm-keeping function
- Defrosting of frozen food
- Load capacity 15 kg

Technical data and dimensions

- Appliance dimensions(H x W x D): 140 x 594 x 542 mm
- Installation dimensions(H x W x D): 140 x 560 – 568 x 550 mm
- Length of connection cable: 175 cm
- „dimensions and installation instructions for this device in accordance with the technical drawing“



Features:

- Front color: Black glass with stainless steel application
- Type: built-in
- Niche dimensions: 140 x 594 x 542 mm
- Dimensions of the device: 140 x 560-568 x 550 mm
- Material of the door: glass with stainless steel application
- Approval certificates: CE, VDE, RCM
- Length of connection cable: 175 cm

Consumption and connection values:

- Electrical connection value: 3350 W
- Voltage: 220-240 V
- Frequency: 50/60 Hz
- Plug type: Schuko / Gardy.m. grounding
- Front color: glass with stainless steel application
- Energy Source: Electric
- Approval certificates: CE, VDE, RCM
- Length of connecting cable: 175 cm
- Niche dimensions: 140 x 594 x 542 mm
- Dimensions of the device: 140 x 560-568 x 550 mm
- Net weight: 30.86 lbs
- Gross weight: 44.09 lbs
- Net weight: 14 Kg
- Gross weight: 20 Kg

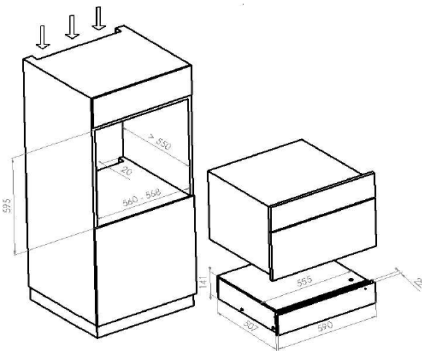

Dimensions in mm